

SWING CLEAR HINGE

- 226-SS (STAINLESS STEEL) (SW2)

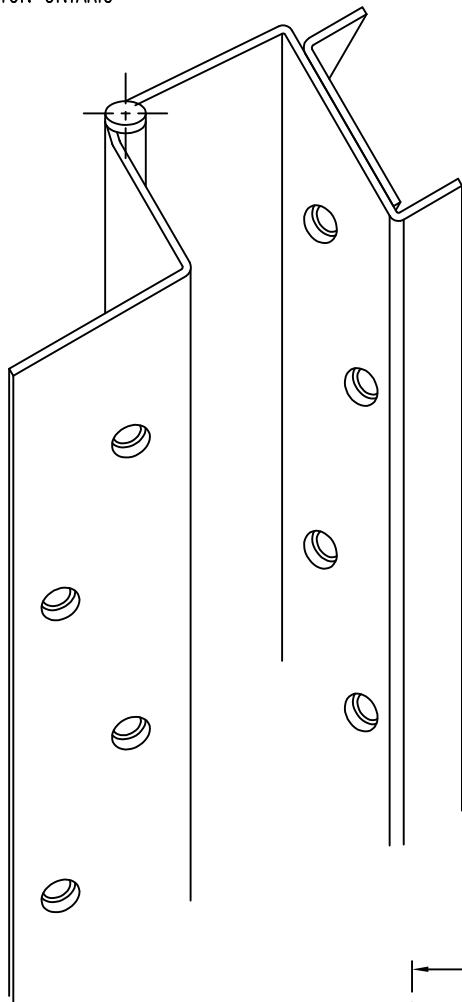

- MATERIAL: 0.075" STAINLESS STEEL
- LENGTHS: 79.160", 83.118", 94.992", 118.740"
CUSTOM LENGTHS AVAILABLE
- HOLES: PIERCED AND COUNTERSUNK FOR # 10 FH SCREW
- ASSEMBLY: ASSEMBLED WITH NYLON WASHERS AND STAINLESS STEEL END CAPS

TYPICAL INSTALLATION
DO NOT SCALE

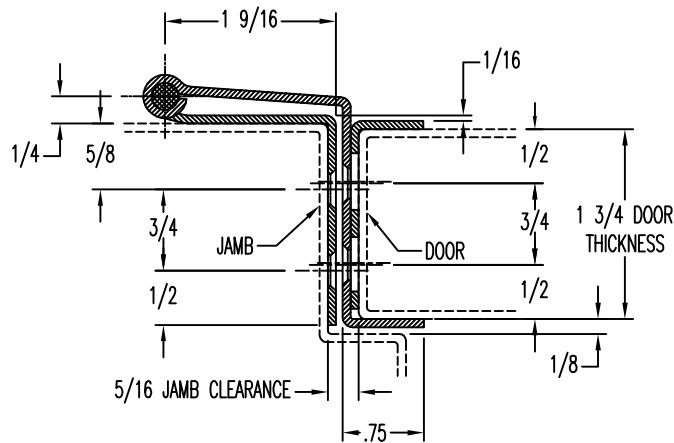
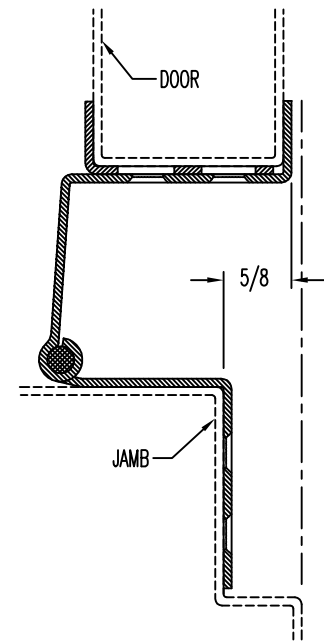

FIRE RATING

- 3 HOURS – HOLLOW METAL DOORS MOUNTED SINGLY
- 90 MINUTES – HOLLOW METAL AND COMPOSITE CORE WOOD FIRE DOORS
- 20 MINUTES – WOOD DOORS

LISTED BY UL/ULC TO THE FOLLOWING CANADIAN AND US SAFETY STANDARDS:

- CAN4-S104-80M – STANDARD METHOD FOR FIRE TESTS OF DOOR ASSEMBLIES
- UL 10C – POSITIVE PRESSURE FIRE TESTS OF DOOR ASSEMBLIES

